

HOHMANN & BARNARD, INC.
a MiTek company

Veneer Anchors

Thermal 2-Seal™ Wing Nut Anchor

Adjustable Veneer Anchor

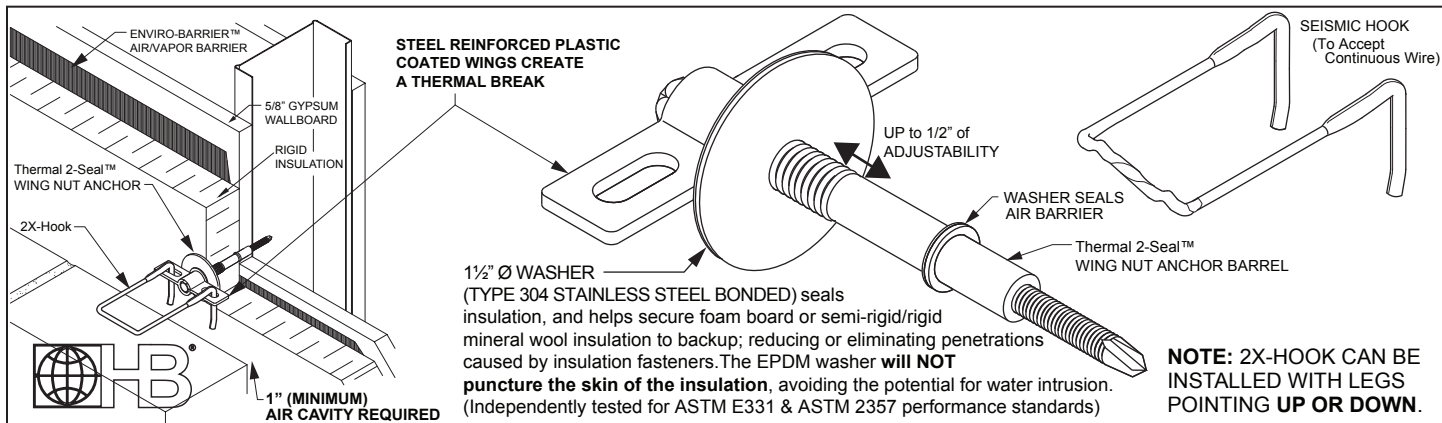

NOTE: 2X-HOOK CAN BE INSTALLED WITH LEGS POINTING UP OR DOWN.

Hohmann & Barnard's 2X-Hook has been tested and designed to withstand over 200-lbf, in tension or compression, at maximum allowed offset (TMS 402/602-16 12.2.2.5.5.4) of 1/4" (disengagement of the pintle from the veneer anchor). These results exceed BIA recommendations and the capabilities of standard "round wire" hooks/pintles by over 100%, while maintaining the ASTM A1064/1064M wire specification.

2-SEAL WING NUT WITH 2X HOOKS (WORKING LOAD*)

CAVITY	0" OFFSET	5/8" OFFSET	1 1/4" OFFSET	TEST
6 1/2"	704#	325#	251#	TENSION
6 1/2"	470#	273#	250#	COMPRESSION

* WORKING LOAD DETERMINED AT .05" DEFLECTION
Tests were completed for 4 1/2" insulation with 2" air cavity.

SCREW PULL-OUT (ULTIMATE LOAD)

STUD GA	18 GA	16 GA	14 GA	12 GA
	611#	743#	1096#	1394#

DRAWINGS FOR ILLUSTRATIVE PURPOSES ONLY

H&B RECOMMENDS 16" X 16" SPACING

Thermal 2-Seal™ Wing Nut Tie - An innovative single screw veneer tie for metal stud construction.

Features: A dual-diameter barrel with factory-installed EPDM washers to seal both the face of the insulation and the air/vapor barrier (an **extra large washer helps secure insulation to backup**). Projecting **Thermal Wings are steel reinforced and coated with highly flame resistant plastic to create a thermal break, decreasing thermal transfer through rigid insulation**. The Wings accept a standard or seismic hook, spin to easily orient pintles/hooks to masonry joints, and provide up to 1/2" of adjustability to account for variations in wall thickness. Install with a standard 5/16" hex socket.

- Barrel (Stainless Steel): ASTM A580/A580M** - AISI Type 304
- Screw (Carbon Steel): ASTM A510 (Carbon Steel) ASTM C954** (1000-hour polymer coating)
- Wire (Carbon Steel):** Prefabricated from cold-drawn steel wire conforming to **ASTM A1064/A1064M**
Tensile Strength - 80,000 p.s.i. | Yield Point - 70,000 p.s.i. minimum
Zinc Coating: Hot-Dip Galvanized after fabrication: **ASTM A153/A153M-B** (1.5 oz/ft²)
- Wire (Stainless Steel): ASTM A580/A580M** - AISI Type 304 or Type 316
- Thermal 2-Seal™ Wing Nut Anchor: US Pat. No. 7,415,803; US Pat. No. 8,910,445**
- 2X-HOOK: U.S. Pat. No. 8,613,175**

Thermal 2-Seal™ Wing Nut Anchor Barrel Finish:

Stainless Steel - Type 304

Thermal 2-Seal™ Wing Nut Anchor Style*:

(Equal to thickness of 5/8" wallboard and/or insulation)

- 5/8" 1" 1 1/2" 2" 2 1/2" 3" 3 1/2"
 4" 4 1/2" 5" 5 1/2" 6" 6 1/2"

*NOTE: This anchor requires a 1" (minimum) air cavity.

Hook Finish:

Hot-Dip Galvanized | Stainless Steel Type 304 Type 316

3/16"Ø Compressed Leg Hook Length:

- 3" (300H-2X) 4" (400H-2X) 5" (500H-2X)
 6" (600H-2X) 7" (700H-2X)

Compressed Leg Seismic Hook: - Length (Model), 3/16"Ø (5mm) wire

- 3" (300-S-2X) 4" (400-S-2X) 5" (500-S-2X)

Continuous Wire Finish: (Diameter 9 ga. 3/16"Ø)

Hot-Dip Galvanized | Stainless Steel Type 304 Type 316

Note: H&B recommends Stainless Steel Wire Ties for maximum protection against corrosion.

IMPORTANT: Since each construction project is unique, the appropriate selection and use of any product contained herein must be determined by competent architects, engineers and other appropriate professionals who are familiar with the specific requirements of the project in question. This drawing and/or data sheet is the confidential and proprietary information of Hohmann & Barnard, Inc. and is not to be reproduced, copied or disclosed, in whole or in part, without the prior written consent of H&B.

HOHMANN & BARNARD, Inc.
CORPORATE HEADQUARTERS
30 Rasons Court | Hauppauge, NY 11788
T: 800.645.0616 F: 631.234.0683
www.h-b.com

Branch/Subsidiary Locations:
ALABAMA - ARIZONA - ILLINOIS
MARYLAND - NEW YORK
PENNSYLVANIA - TEXAS - UTAH
CANADA

© 2013-2019 MiTek®