

Outside Corner

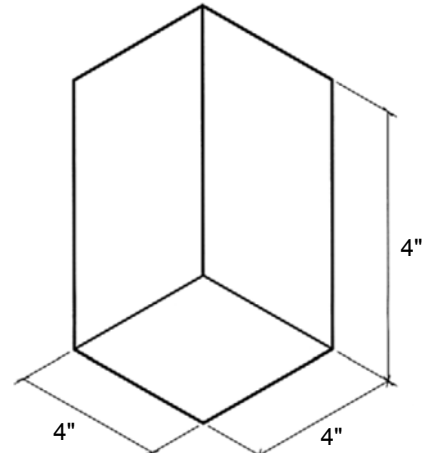

End Dam

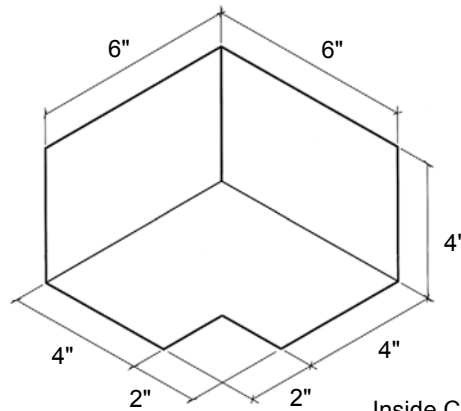

Inside Corner

DRAWINGS FOR ILLUSTRATIVE PURPOSES ONLY

Stainless Steel and Copper Corners & End Dams

Blok-Lok® Stainless Steel and Copper Corners & End Dams are pre-fabricated soldered inside corners, outside corners and end dams suitable for all Blok-Lok flashings. Simply place underneath flashing for the ultimate protection against moisture penetration.

Stainless Steel

- Corners and End Dams are made of 26 ga (18 mil) Type 304 Stainless Steel - ASTM A 240, ASTM A 666, ASTM A 480, ASTM A 167
- Can be used with: Flex-Flash® Flashing, Textroflash™ Flashing, Textroflash™ Green Flashing, and Stainless Metal Flashing.
- Per the International Stainless Steel Forum, Stainless Steel objects have an average of 60% recycled content.

Copper

- Corners and End Dams allow for smooth transition with flashing as opposed to 60 mil fabrics.
- Can be used with: Copper-Tuff™ Flashing, Copper-Tuff™ SA Flashing, Copper-Flex™ Flashing, C-Fab™ Flashing, and Copper Metal Flashing.

Stainless Steel

- Inside Corner
- Outside Corner
- End Dam

Copper

- Inside Corner
- Outside Corner
- End Dam

Corners and End Dams are packaged 25 pieces per box.